



# StandByMe

EXHIBITION STANDS, SIMPLIFIED



"SPEED & EFFICIENCY"



"VISUAL IMPACT"



"FLEXIBILITY"



"MODULARITY"



"SUSTAINABILITY"



"TURNKEY SOLUTION"



 **StandByMe**  
simplify your exhibition

# Modular & Rental Solution

*"The Intelligence of Modular  
with the Convenience of Rental."*

**StandByMe** is a high-performance modular ecosystem designed for those seeking speed and sophistication. We combine versatile engineering structures with a comprehensive furniture and technology rental catalogue, ensuring a ready-to-use space with high visual impact.

## KEY DIFFERENTIATORS



"SPEED & EFFICIENCY"



"VISUAL IMPACT"



"FLEXIBILITY"



"MODULARITY"



"SUSTAINABILITY"



"TURNKEY SOLUTION"



Executed Project:  
**Portuguese Parliament** (Assembleia da República)  
Lisbon, Portugal



Executed Project:  
**Lectra - MAQUITEX**  
Exponor, Porto, Portugal



Executed Project:  
**Lectra - MAQUITEX**  
Exponor, Porto, Portugal

# Configurations & Versatility: *Structural Solutions & Technology*

The StandByMe system goes beyond traditional walls, offering integrated solutions for a 360° experience:

**FUNCTIONAL WALLS WITH NICHE & SHELVING:** Modular structures that allow for integrated niches and shelving with hidden LED lighting, ideal for premium product displays.

**FLOORING SOLUTIONS:** Technical or decorative flooring systems that ensure a perfect finish and total concealment of all cabling.

**ILLUMINATED CEILINGS & LED CURTAINS:** Creation of immersive environments through ceiling structures with integrated lighting or large-format LED curtains for a dynamic visual effect.

**MULTIMEDIA INTEGRATION:** Native supports for TV monitors and screens, perfectly embedded into the structure for a clean, high-tech look.

STRUCTURE



+ LIGHTING



+ CLADDING





STRAIGHT WALL SOLUTIONS



STRAIGHT & CURVED WALL SOLUTIONS

# The Strategic Choice *for Companies on the Move*

**StandByMe** is the strategic choice for brands that refuse to compromise on design for the sake of agility. Designed for exhibitors with an active events calendar, this solution unites the visual impact of a bespoke stand with the optimised logistics of a modular system.

## THE IDEAL SOLUTION FOR COMPANIES SEEKING:

**HIGH-PERFORMANCE EXHIBITION:** Highlight products sophisticatedly with illuminated niches.

**EXPERIENCE & TECHNOLOGY:** Spaces focused on visitor comfort with fluid tech integration.

**TURNKEY PROFITABILITY:** The perfect balance between cost-effectiveness and full, worry-free management.

**SUSTAINABILITY WITH DIFFERENTIATION:** Durable, reusable materials that reinforce environmental commitment.



6x3 metre CONFIGURATION



9x3 metre CONFIGURATION



3x3 metre CONFIGURATION

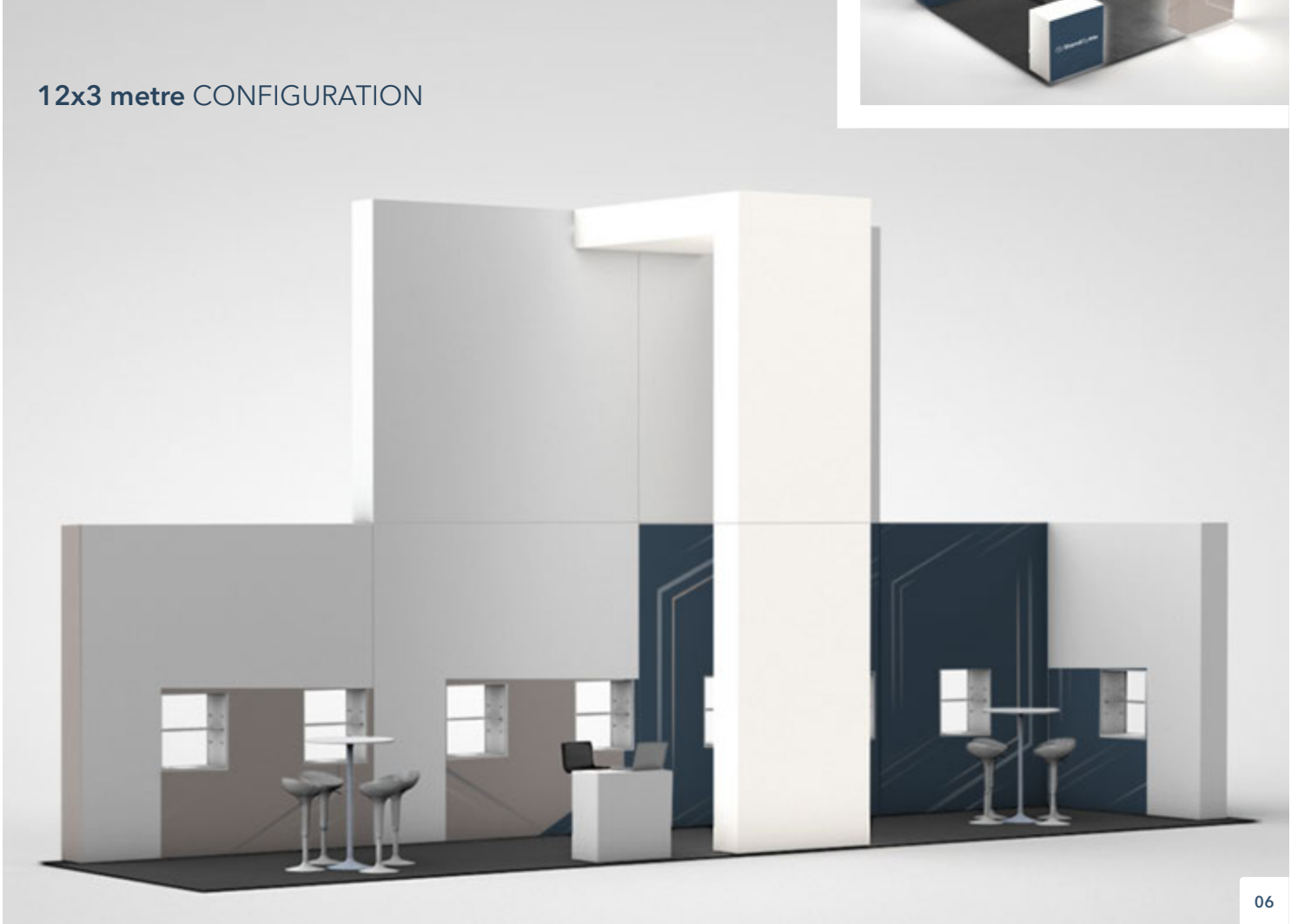

12x3 metre CONFIGURATION

# A Modular *Plug & Play System*

The **StandByMe** system consists of structural solutions, cladding, and accessories for Floors, Walls, and Ceilings.

Assembly is done through Plug & Play fasteners, with no tools required.

**01.** Unpack + **02.** Set up Structure +  
**03.** Install LEDs + **04.** Attach Printed Fabric





## PLUG&PLAY MODULAR FLOORING

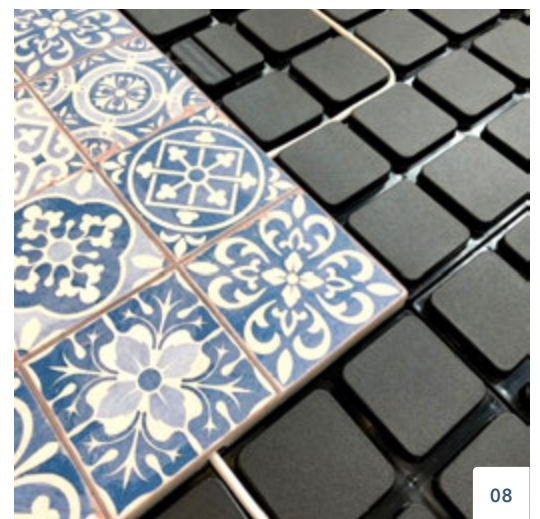

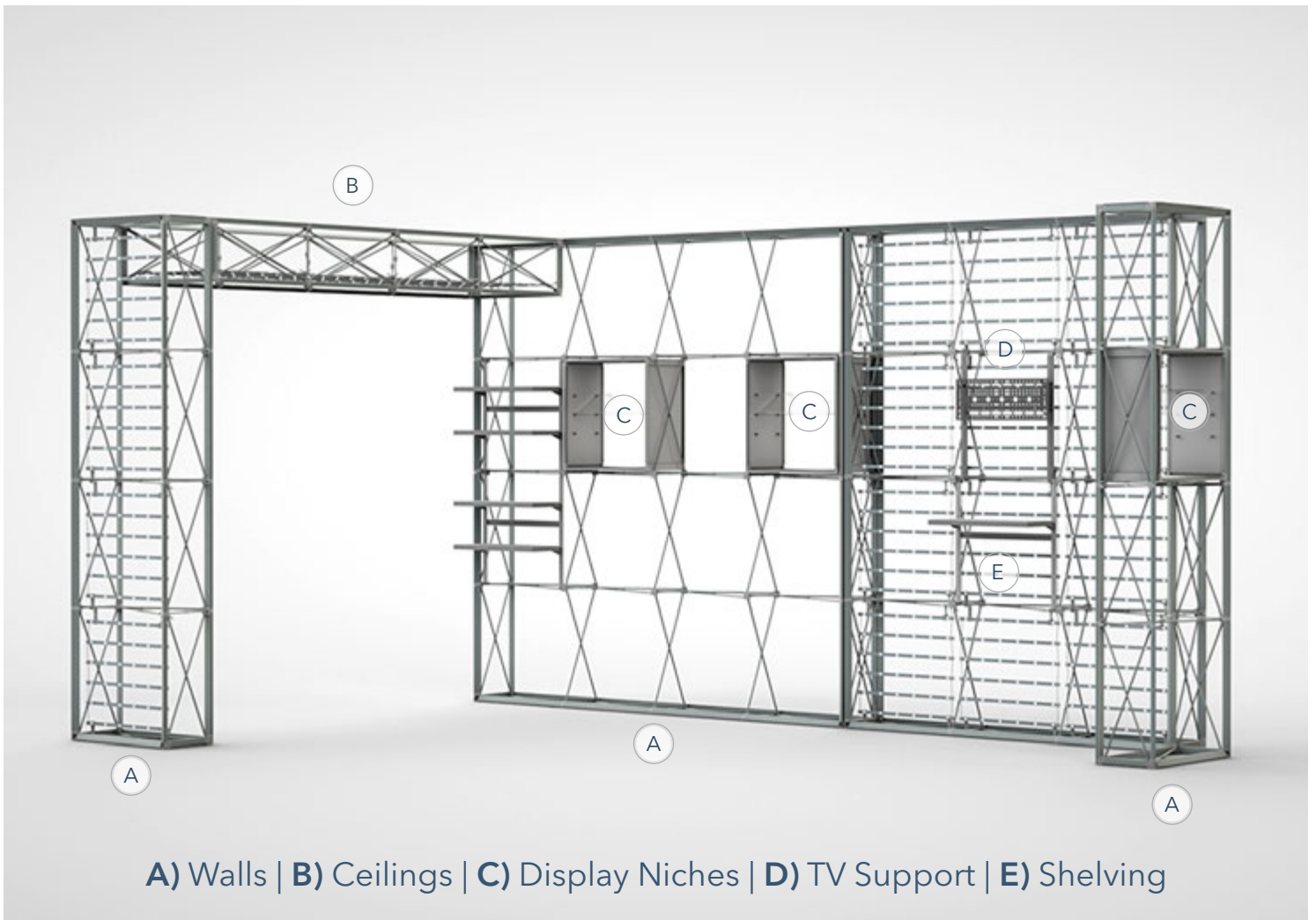

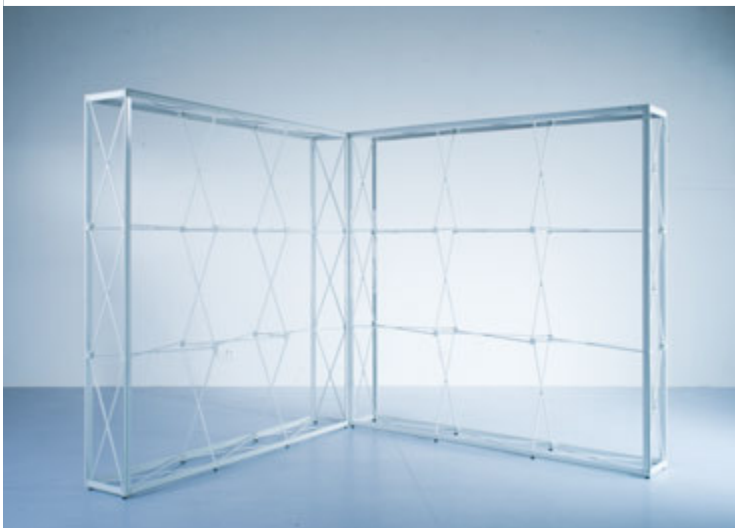
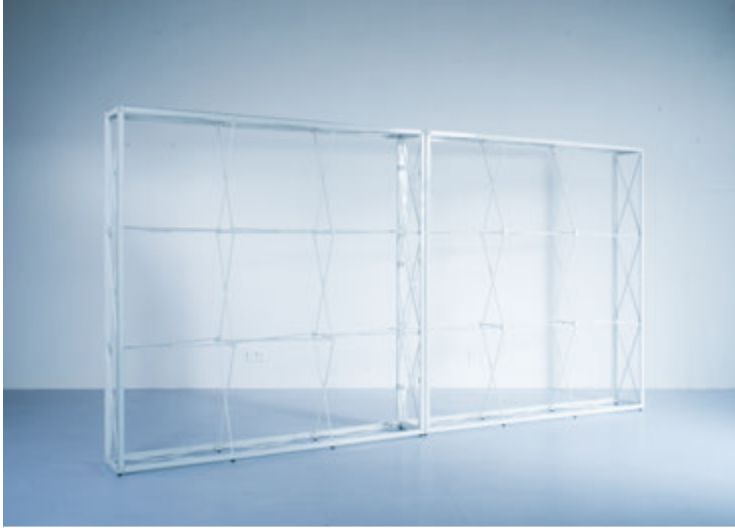
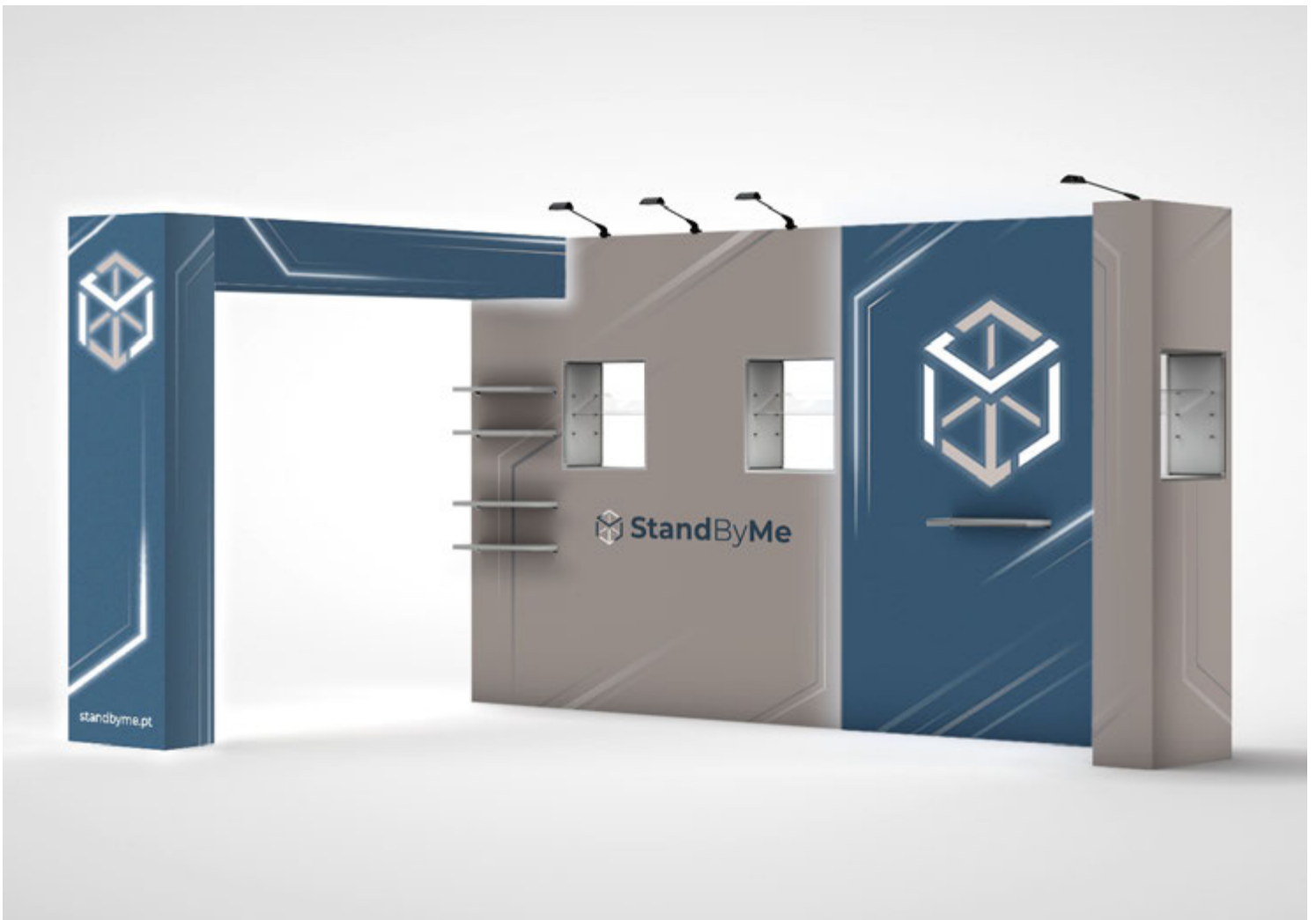

# Adapt to Any Space

*by combining straight and curved modules*

## INFINITE CONFIGURATIONS | ADAPT TO ANY SPACE

Combine straight and curved modules to create functional, bespoke layouts that respect your space's geometry. The **StandByMe** system allows you to transform square metres into organic or orthogonal experiences without compromising stability.

## COMMANDING PRESENCE | DIMENSION & IMPACT | GO BEYOND THE HORIZONTAL PLANE.

Thanks to the modular nature of the system, you can stack modules to gain height, creating imposing structures that ensure maximum visibility in any exhibition hall.

## MODULAR GEOMETRY | BESPOKE LAYOUTS

The strategic combination of straight and curved modules allows for total adaptation to any hall configuration. The **StandByMe** system was designed to be intuitive, enabling organic or orthogonal layouts without compromising stability.

## STRATEGIC VERTICALITY | VERTICAL SCALABILITY | ELEVATE YOUR BRAND.

The system allows for the secure stacking of modules, enabling the creation of stands with multiple height levels. Gain visual prominence and stand out on the exhibition's skyline.

### PLAN VIEWS: POSSIBLE CLADDING METHODS FOR STRUCTURES USING FABRICS PRINTED WITH YOUR EVENT GRAPHICS AND IMAGES



Front Fabric / Graphic

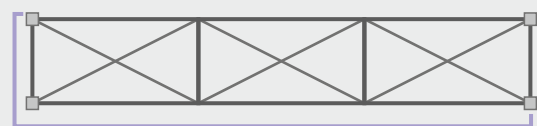

Front Fabric / Graphic + 1 Side



Front Fabric / Graphic + Separate Sides



Front Fabric / Graphic + Sides

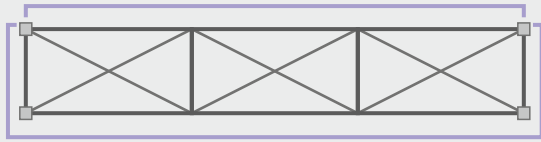

Full Fabric / Graphic Wrap with Separate Back

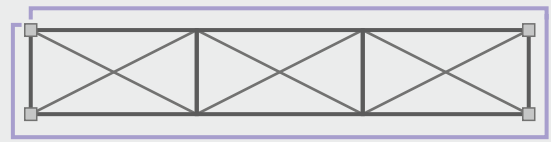

Full Fabric / Graphic Wrap

## STRUCTURAL DRAWINGS & DIMENSIONS

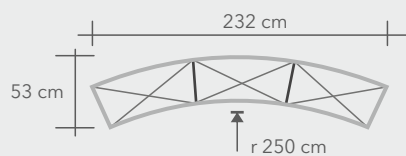
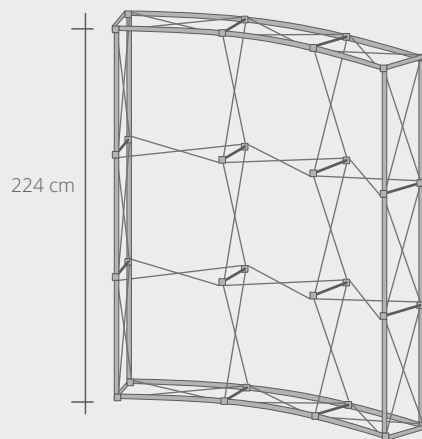
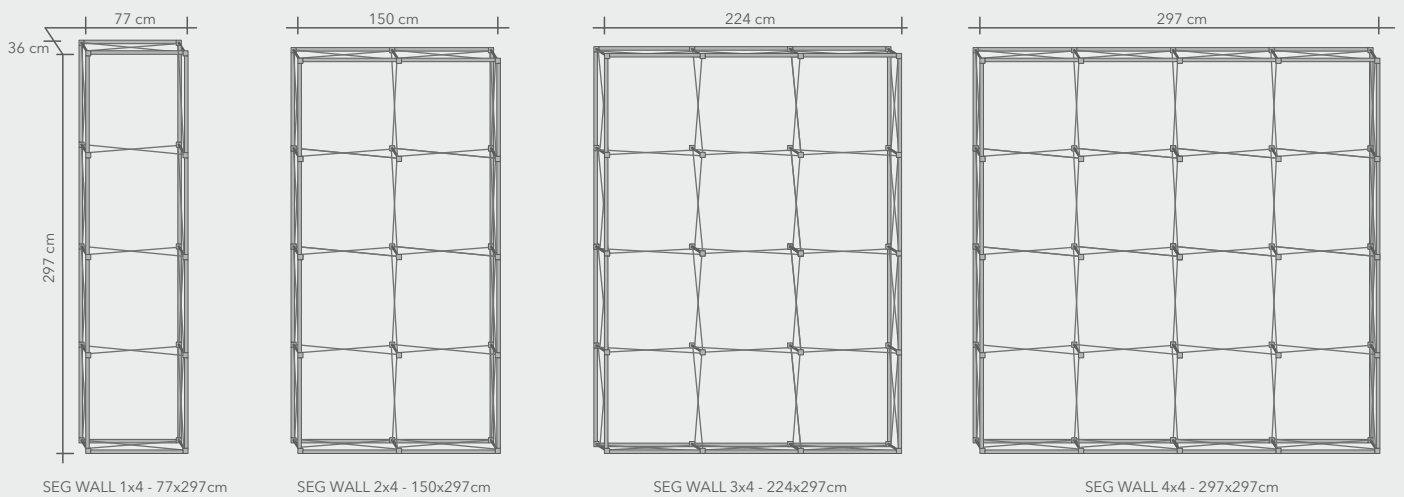
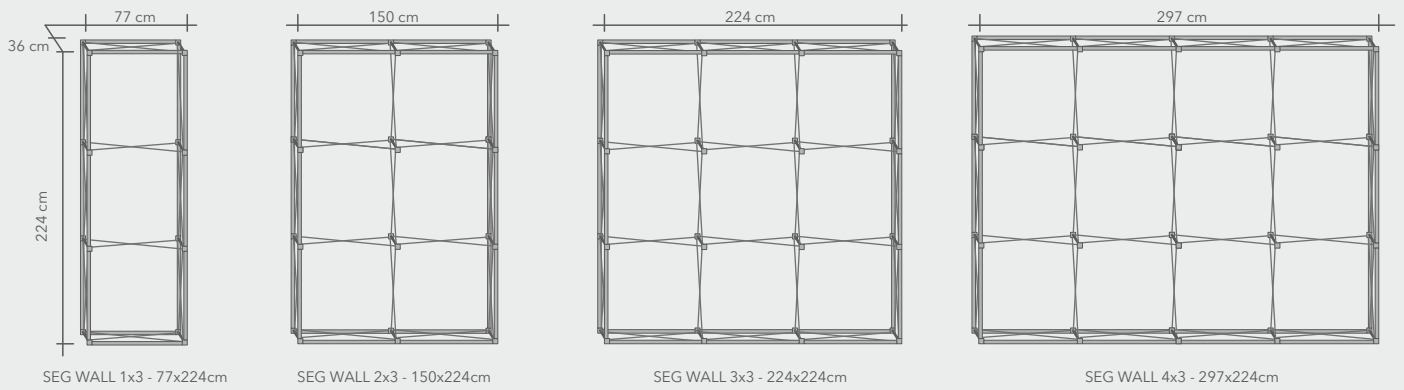

SEG WALL CURVE 3x3 - 224x224cm

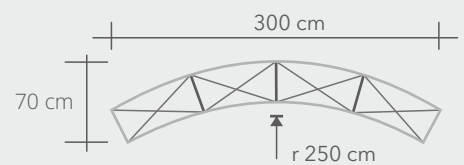
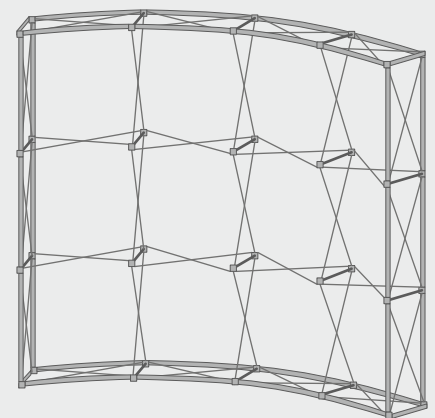

SEG WALL CURVE 3x4 - 224x297cm

# Integrated Lighting, *Full or Partial*

Lighting is an essential part of the StandByMe experience:

INTERNAL & EXTERNAL LEDS TO HIGHLIGHT KEY AREAS.

LED CURTAINS FOR IMMERSIVE ENVIRONMENTS.

ILLUMINATED NICHEs FOR FEATURED PRODUCTS.

DIRECTIONAL SPOTLIGHTS FOR GREATER VISIBILITY AND SPECIFIC, LOCALISED LIGHTING.

TEXTILE CLADDING

LED CURTAIN

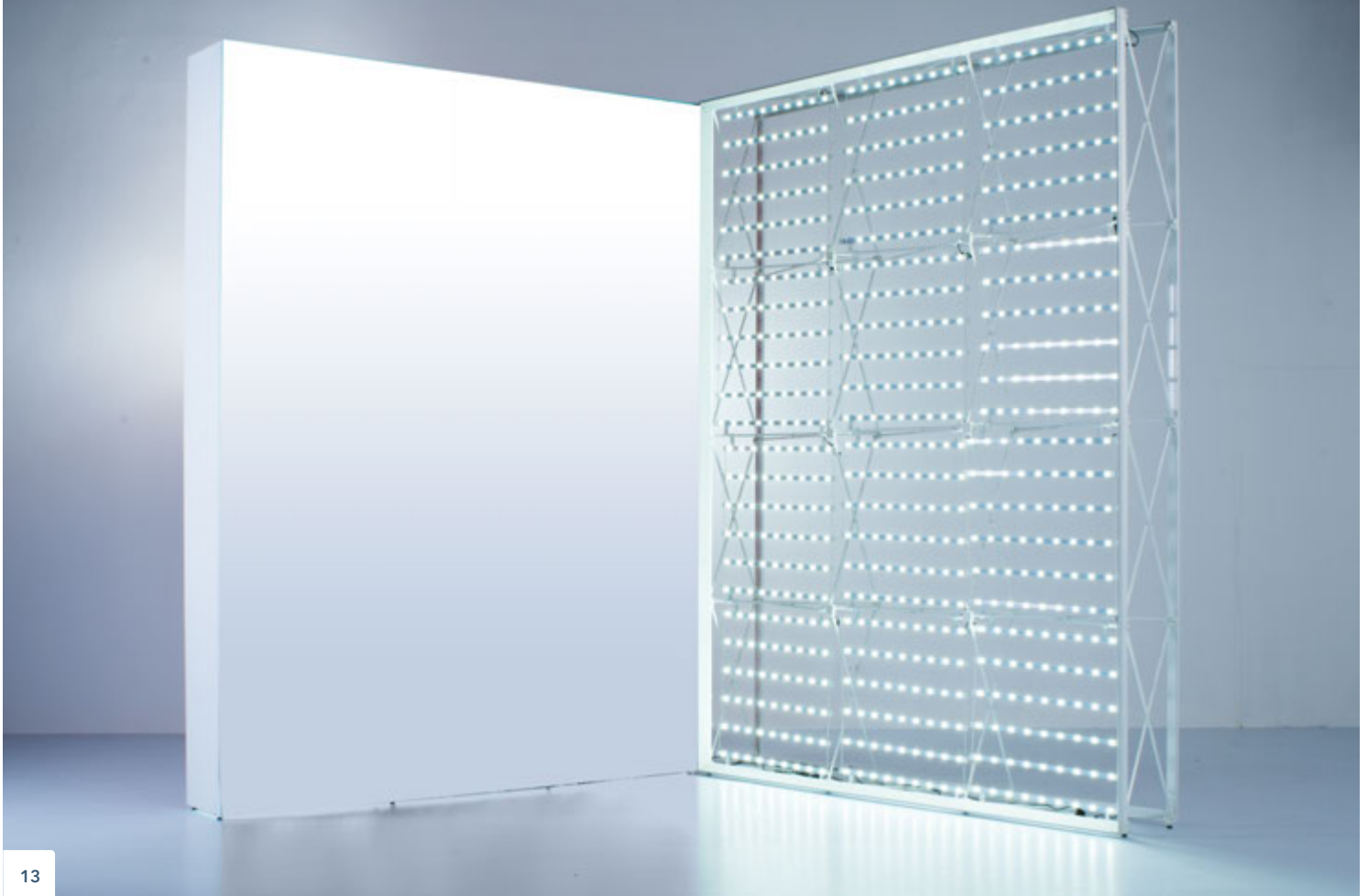



LED MODULES / INTERNAL CURTAINS



EXTERNAL DIRECTIONAL LED SPOTLIGHTS



ILLUMINATED DISPLAY  
NICHES

# Accessories & Add-ons, Furniture & Accessory Hire

Access a comprehensive range of furniture without the need for investment or storage:

**DESIGNER FURNITURE:** Meeting tables, chairs, bar stools, and ergonomic sofas featuring the latest trends.

**COUNTERS & RECEPTION:** Configurable modules with options for integrated fridges and coffee machines, customised with your branding.

**SMART STORAGE:** Cloakroom areas and discreet storage zones, seamlessly integrated into the stand's design.



↑ PÉS DE SUSTENTAÇÃO

↓ ARRUMO COM PORTA

↓ PORTA DE ARRUMO

↓ SUPORTE MONITOR TV

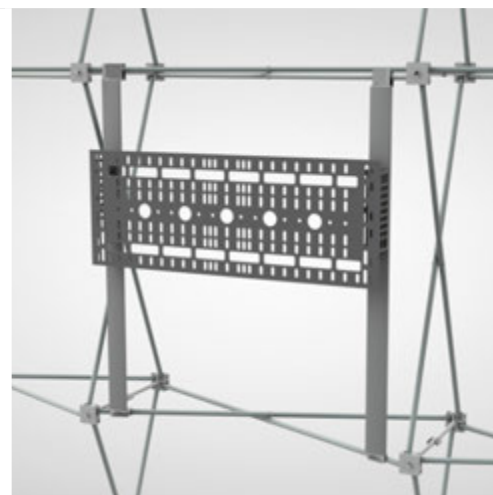
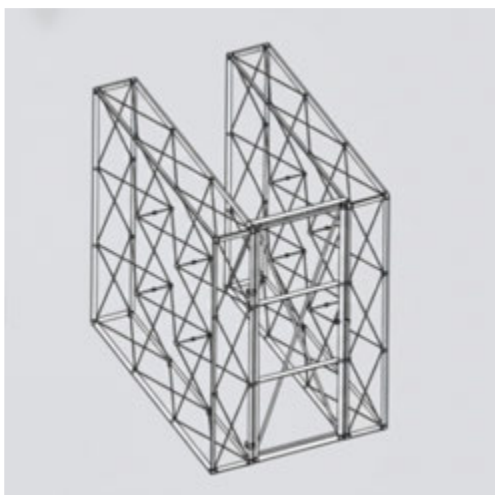



↑ BANCOS COM ARRUMOS

↑ PRATELEIRAS

↑ NICHOS EXPOSITORES

↓ ESTANTES



# Accessories & Add-ons

## Counters

The **StandByMe** system features two standard sizes of reception counters, which can be internally illuminated and fully customised with digital printing.

ALL COUNTERS ARE EQUIPPED WITH AN INTERNAL SHELF.

SELECTED COUNTERS CAN ALSO ACCOMMODATE COFFEE MACHINES AND FRIDGES

**01.** Unpack + **02.** Assemble the Frame + **03.** Install the LEDs  
+ **04.** Install the Countertop + **05.** Fix the Printed Fabric



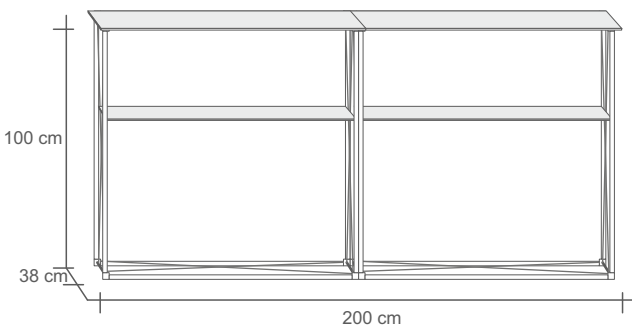
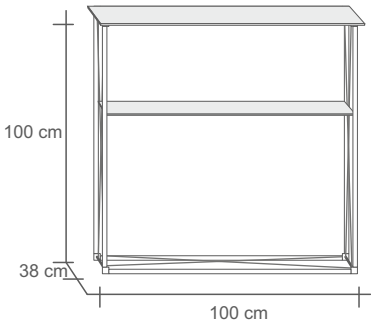



Executed Project:  
**CM-Maia - Education QUALIFICA**  
Exponor . Porto . Portugal



Executed Project:  
**36th International Epilepsy Congress (IEC)**  
Lisbon Congress Centre . Lisbon . Portugal



Executed Project:  
**CM-Maia - Tourism XANTAR**  
Ourense . Spain



Executed Project:  
**Ufesa - Expo Euronics Europarque**  
Santa Maria da Feira . Portugal

# Frequently Asked Questions

HOW LONG DOES IT TAKE TO ASSEMBLE A STAND? Thanks to our quick-connect modular system, most configurations can be assembled in just a few minutes or hours, depending on the size. Unlike traditional stands, there is no drying time, painting, or excessive noise involved.

DO I NEED SPECIAL TOOLS TO ASSEMBLE THE STRUCTURE? *No.* **StandByMe** was designed to be intuitive. The structure uses smart connectors that eliminate the need for complex tools, allowing for a clean and silent assembly.

CAN THE GRAPHIC DESIGN BE CUSTOMISED FOR EACH EVENT? *Absolutely.* We use high-definition tension fabric panels that can be easily swapped. This allows you to use the same modular structure for different trade fairs by simply changing the visual communication and messaging.

HOW DOES FURNITURE HIRE WORK? We offer a diverse catalogue ranging from counters and tables to lounge solutions. During the planning stage, you choose the pieces that best suit your goals, and we handle the delivery, assembly, and collection at the event venue.

DOES THE SYSTEM SUPPORT TECHNOLOGICAL EQUIPMENT (TVS, TABLETS)? *Yes.* **StandByMe** features native, integrated mounts for TV monitors and screens. Furthermore, all cabling remains hidden inside the structure or under the technical flooring, ensuring a professional and organised appearance.

IS LED LIGHTING INCLUDED? We offer various lighting solutions that can be integrated as needed: from panel backlighting (lightboxes) to directional spotlights and LED curtains for creating dynamic environments.

CAN THE STAND BE ADAPTED TO DIFFERENT SPACE SIZES? That is the great advantage of **StandByMe**. As a modular system, you can use the same components to create a 9sqm stand for one event and a larger 24sqm configuration for another, simply by adding or removing modules.

IS THE SYSTEM ENVIRONMENTALLY FRIENDLY? *Yes.* By choosing **StandByMe**, you avoid the waste common in traditional stand construction (single-use wood and plastics). *Our structures are 100% reusable, and our furniture hire model promotes a circular economy.*

# Check-list StandByMe:

Everything under control for your event

*Before the doors open to the public, we ensure every detail is in place. Know exactly what your solution includes:*

## 1. STRUCTURE & BRANDING

- Structural Modules:** High-resistance aluminium frames (straight or curved).
- Graphic Design:** High-definition printing on tension fabric.
- Walls with Niches:** Built-in spaces for product display.
- Technical/Decorative Flooring:** Levelled flooring with hidden cabling.

## 2. LIGHTING & TECHNOLOGY

- Integrated Lighting:** Low-consumption LEDs built into the frame and niches.
- Visual Highlights:** Directional spotlights or high-impact LED curtains.
- Multimedia Mounts:** Integration for TV monitors, tablets, or interactive screens.
- Connectivity:** Strategically positioned power points.

## 3. FURNITURE & COMFORT (RENTAL)

- Designer Furniture:** Chairs, tables, stools/sofas according to the chosen layout.
- Reception Counter:** With internal storage and custom branding.
- Hospitality Area:** Optional integrated fridge and coffee machine within the counter.
- Storage Zone:** LED-lit coat racks and shelving for promotional materials.

## 4. TURNKEY SERVICE

- 3D Project:** Pre-visualisation of the stand for full validation.
- Transport Logistics:** Delivery and collection at any location.
- Assembly & Dismantling:** Professional technical team (fast, clean, and silent).
- Stock Management:** Maintenance and storage of graphic panels for your next event..



EXHIBITION STANDS, SIMPLIFIED

# "Simplify Your Exhibition, Maximize Your Impact."

"Forget logistical complexity and time-consuming assembly. With **StandByMe**, your only concern will be welcoming your visitors. We handle the rest."

TALK TO A SPECIALIST NOW



"SPEED & EFFICIENCY"



"VISUAL IMPACT"



"FLEXIBILITY"



"MODULARITY"



"SUSTAINABILITY"



"TURNKEY SOLUTION"

Zona Industrial do Xisto,  
Travessa Cesário Verde, 97  
4470-522 Maia . PORTUGAL

Tl.m. +351 96 50 22 34 7

Tel. +351 22 948 50 80



ADDITIONAL SERVICES

01. CONSULTANCY & PLANNING

02. GRAPHIC DESIGN & COMMUNICATION

03. VIDEO & MULTIMEDIA  
Production of Promotional, Corporate,  
and Training Videos.

Creation of Animations and  
Motion Graphics.

Video and Audio Editing.

geral@standbyme.pt

www.standbyme.pt

## SMART PROSPECTING & VISITOR INVITATIONS

Attract more qualified  
visitors to your stand with  
targeted and authorized  
campaigns before  
the trade fair.

